



## 2014 17<sup>th</sup> ANNUAL SKILLS MANITOBA COMPETITION CONTEST SCOPE

**CONTEST NAME:** Autobody Repair

**CONTEST NO:** 13

**CATEGORY:** Secondary and Post-Secondary  
Maximum number of competitors Secondary – 10  
Maximum number of competitors Post-Secondary - 10

**CONTEST LOCATION:** Red River College - Notre Dame Campus – Building J

**CONTEST START TIME AND DURATION:**  
6 hours

**PURPOSE OF CHALLENGE:**  
To assess the competitor's skills in performing various auto body repair tasks.

**SKILLS AND KNOWLEDGE TO BE TESTED:**  
The contest is divided into four sections:

- a) Rocker Panel Repair Project – Duration 1.5 hours
- b) Metal Panel and Plastic Repair – Duration 1.5 hours
- c) Measuring and Damage Analysis – Duration 1.5 hours
- d) Theory Exam – Duration 0.5 hours

Rocker Panel Project Schematic can be obtained from Tom Smith (204) 326-6426 or John Wetervelt (204) 746-8106.

**POINT BREAKDOWN / 1000 TOTAL:**

Rocker Panel Project	300 points
Metal Panel and Plastic Repair	300 points

Measuring 300 points  
Theory Exam 100 points

**NATIONAL COMPETITION ELIGIBILITY:**

- A mark of **70% or higher** must be scored by the gold medalist in each contest in order for them to attend the National Skills Competition

**EQUIPMENT, TOOLS, MATERIALS TO BE PROVIDED BY COMMITTEE:**

- 110 volt power supply
- Compressed air
- MIG welding unit
- Air control equipment
- Work table
- Protective equipment other than individual protective gear

**EQUIPMENT, TOOLS, MATERIALS TO BE SUPPLIED BY COMPETITOR:**

- All individual safety equipment required to perform work in industry-approved conditions.
- All personal auto body repair technician's tools
- Electric or compressed-air drill and grinder with attachments and supplies

**WORKSITE SAFETY RULES / REQUIREMENTS:**

- Must meet industry standards

**SPECIAL CONDITIONS / ADDITIONAL INFORMATION:**

**2014 SKILLS CANADA MANITOBA AUTOBODY CONTEST**

**METAL WORKING**

Duration of test: 1.5 hours (shared with plastic repair)

The students involved in this section of the competition will perform two minor repairs on a metal repair panel. This test will determine the skill level of the student performing hammer and dolly work and the mixing, application, sanding and finishing of body filler.

Description of test:

- the larger dent on the right side of the panel is to be straightened with the tools provided.
- the smaller dent on the left side is to be filled with body filler

Material Provided:

- replacement repair panel
- body filler
- metal working tools

Safety:

Students will be provided with the following equipment:

- safety glasses
- safety shield
- ear protection
- respirator
- leather and rubber gloves

Hint: It is advisable for the student to properly mix the body filler and fill the small dent on the left side of the panel. While the body filler dries, the student should concentrate on straightening the larger dent – switching back and forth if necessary.

Part I: The objective of this portion of the test is for the student to straighten the damaged area on the right side of the panel.

Instruction: Using the methods learned at the trade school, the student is expected to straighten the damaged area as close as possible to its original condition. **Note: No fillers are to be used on this dent.**

Part II: The objective of this portion of the test is to fill the dent with body filler and sand the body filler to a smooth finish.

Instruction: The student should properly mix body filler and apply it to the dent. After sufficient drying time, the body filler is to be sanded to a smooth and even finish.

Note: The student should not attempt to straighten this dent before applying the filler.

## 2014 SKILLS CANADA MANITOBA AUTOBODY CONTEST

### Plastic Identification and Repair

This section on plastic repair will have a 1.5 hr time limit shared with the metal working project in which the student will determine and carry out a two-sided TPO bumper repair and TPO bumper repair.

Each student will be provided with a section of a TPO bumper with an approximate 5 inch cut through it. The cut will extend from, through the edge, and towards the center of the test piece. Students must perform a two-sided chemical repair using the product of their choice. The student must then prepare the tear by vee-ing out the area, featheredging, properly cleaning, applying reinforcement tape and applying chemical repair. Once the inside repair is completed, the student will duplicate the

repair on the outside of the test piece. When dry, the student will sand the repaired area until satisfied and present to judge for scoring before applying finishing filler.

The student will be graded on the following:

- Determining the proper repair procedure and preparation of test piece
- Vee-ing of tear
- Proper featheredging
- Cleaning of test piece
- Application of reinforcement tape
- Application and preparation of chemical repair (inside and outside)
- Application of finishing filler

Safety: Students must wear safety shoes and neat clothes (no cuffs) and the following safety equipment:

Safety glasses must be worn when:

- Blowing off bumper
- Grinding of bumper
- Featheredging, applying chemical repair and applying finishing filler

Gloves must be worn:

- During cleaning procedures
- Applying chemical repair and applying finishing filler
- During clean-up procedures

Respirators must be worn:

- When preparing bumper
- During featheredging bumper
- During grinding
- While applying chemical repair and finishing filler (Repair will be inspected before application of finishing filler).

## **2014 SKILLS CANADA MANITOBA AUTOBODY CONTEST**

### **Vehicle Structural Alignment and Assessment**

This section will determine the student's knowledge of vehicle alignment and assessment. The student will have to determine the type of damage conditions to a vehicle clamped in the frame machine. Students will be provided with frame measuring equipment such as:

1. Tape measure
2. Tram gauge
3. Frame spec sheet
4. Safety equipment
5. Clipboard, assessment sheet and pencil

Note: The frame gauges will be pre-hung on the vehicle for the competition, students must describe the condition.

Example:

- Sideway (front/rear)
- Sag (front/rear)
- Mash (front/rear)
- Twist
- Diamond
- Knee Back (set back)
- Strut Tower Width

The vehicle mounted on the frame rack has what type of damage

- Direct damage
- Indirect damage
- Both

Safety:

Students will be provided with the following equipment:

- Safety glasses
- Hard hat

Note: Students must have their own protective foot wear.

## **2014 SKILLS CANADA MANITOBA AUTOBODY CONTEST**

### **Required Tool and Safety List for Competitors**

- All personal safety equipment
- Random orbital sander
- Pistol grip grinder
- Die grinder and bits/cut-off wheel
- Air/electrical drill
- Assortment of twist drills
- Assortment of vice grips
- Tape measure
- Straight edge
- Tri-square
- Welding helmet
- Hacksaw/blades
- Spot-welder cutter
- Felt marker/pencil
- Body hammer
- Pick hammer
- Metal file

- Dollies
- Blowgun
- Block sander
- Cheese grater
- Board sander
- Squeegee metal/plastic
- Mixing board
- Centre punch
- Utility knife/razor blade
- Cold chisel

Safety:

- Dust masks
- Safety glasses
- Respirator charcoal – use whenever mixing
- Coveralls
- Welding mask
- Hearing protection
- Leather gloves
- Disposable gloves
- Safety footwear
- Face shield

## **2014 SKILLS CANADA MANITOBA AUTOBODY CONTEST**

<b>Equipment Supplied by Organizers</b>
---

- Air compressor
- Air regulators and cleaners
- Air hose and connections
- Work benches with vices
- Panel stands
- Air extractors
- Infra-red lamps
- Brooms and dust pans
- Garbage cans
- Tables (5) and chairs (20)
- Tram gauges
- Clipboard
- Blowgun

## Skills Canada Manitoba Autobody Contest

### Rocker Panel Sectioning Project

Time Limit 1.5 hrs.

This project is designed to test a student's abilities to measure, cut, drill out spot welds and weld. A 70 mm section of the "rocker panel" assembly must be removed from one end. A replacement "rocker" section will be provided and must be cut to fit. An inner reinforcing piece must be cut to fit. An inner reinforcing piece must be made up from a piece of the replacement "rocker". The reinforcing piece should be cut and attached as per generally accepted guidelines. The replacement parts will be MIG welded using 16 plug welds and butt welded with backing.

**Note:** This project must remain clamped in a vise throughout the test. This is to provide cutting, drilling and welding in flat, vertical and overhead positions for evaluation.

Only a MIG welder and a vise to hold the project will be provided. The contestant must provide all other tools.

### SKILLS MANITOBA 2004 AUTO BODY COMPETITION SECTIONING SCOPE

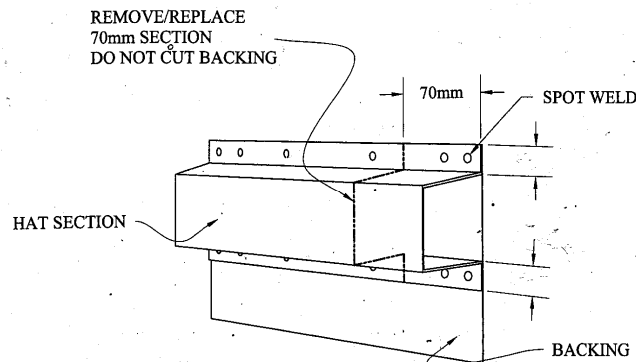

Section the rail provided at the location indicated in the above drawing. You are to section seventy millimeters (70 mm) of the hat section only. Do not cut the backing. A six inch piece of replacement channel has been provided for you to create a replacement as well as the necessary reinforcement.

*Generally Accepted sectioning guidelines.*  
Please use I-CAR sectioning guidelines.

## **THE IMPORTANCE OF ESSENTIAL SKILLS FOR CAREERS IN THE SKILLED TRADES;**

Essential skills are used in nearly every job and at different levels of complexity. They provide the foundation for learning all other skills and enable people to evolve with their jobs and adapt to workplace change. Good Essential Skills means you will understand and remember concepts introduced in technical training. The level of Essential Skills required for most trades is as high as or higher than it is for many office jobs.

The following 9 skills have been identified and validated as key essential skills for the workplace:

Numeracy, Oral Communication, Working with Others, Continuous Learning, Reading Text, Writing, Thinking, Document Use, Digital.

Top Essential Skills for Autobody Repair ; Document Use, Thinking : Decision Making, Job Task Planning and Organizing

## **FOR MORE INFORMATION PLEASE CONTACT TECHNICAL COMMITTEE MEMBERS:**

**Lawrence Danylchuk**                      586-0423 or [mailme@mts.net](mailto:mailme@mts.net)

**Ernie Monkman**                         632-2224 or [emonkman@rrc.mb.ca](mailto:emonkman@rrc.mb.ca)